

# RadioLink

## A560

3D Fixed Wing Vertical Flight with 1 Switch

Instruction Manual



**CE FCC RoHS**

\* Note: There are 2 versions of A560, including RTF version and PNP version.

Please refer to page 3-22 of this manual for RTF version, and page 23-27 for PNP version.

## A560(RTF) CONTENTS

Disclaimer and Warning .....	3
Packing List .....	4
Chapter 1 General Introduction .....	5
1.1 Motion Principle of Fixed Wing .....	5
1.1.1 Aileron .....	5
1.1.2 Elevator Servo/Horizontal Tail .....	5
1.1.3 Rudder Servo/Vertical Tail .....	5
1.1.4 Drive Principle .....	6
1.2 A560 Units .....	6
1.3 Usage of A560 Units .....	7
1.3.1 Notice for Use .....	7
1.3.2 Transmitter & Receiver .....	7
1.3.3 Flight Controller Byme-A .....	8
1.3.4 Motor .....	8
1.3.5 ESC .....	9
1.3.6 Servo .....	9
1.3.7 Propeller .....	9
1.3.8 Battery .....	10
1.3.9 Charger .....	10
Chapter 2 A560 Assembly .....	11
Chapter 3 Flight Mode .....	11
3.1 Flight Mode Setting .....	11
3.2 Five Flight Modes .....	12
3.2.1 Vertical Mode .....	12
3.2.2 Stabilize Mode .....	14
3.2.3 Gyro Mode .....	15
3.2.4 Acrobat Mode .....	16
3.2.5 Manual Mode .....	16
Chapter 4 Flight Precautions .....	16
Chapter 5 Servo Phase .....	17
5.1 Transmitter Phase .....	17
5.1.1 Transmitter Phase Setup .....	17
5.1.2 Transmitter Phase Test .....	17
5.1.3 Transmitter Phase Adjustment .....	19
5.2 Flight Controller Phase .....	20
5.2.1 Flight Controller Phase Test .....	20
5.2.2 Flight Controller Phase Adjustment .....	21
Chapter 6 Flight Controller Calibration .....	22
6.1 Power-on Calibration .....	22
6.2 Attitude Calibration .....	22

## A560 (PNP) CONTENTS

A560 (PNP) Instruction Manual .....	23
Disclaimer and Warning .....	23
Packing List .....	23
Chapter 1 General Introduction .....	23
Chapter 2 A560 Assembly .....	23
Chapter 3 Flight Mode .....	23
3.1 Receiver Connection .....	23
3.2 Transmitter Setup .....	24
3.2.1 Model Type Setup .....	24
3.2.2 Transmitter Phase Setup .....	24
3.3 Flight Mode .....	24
3.3.1 Flight Mode Setting .....	24
3.3.2 Five Flight Modes .....	25
Chapter 4 Flight Precautions .....	25
Chapter 5 Servo Phase .....	26
Chapter 6 Flight Controller Calibration .....	26
6.1 Power-on Calibration .....	26
6.2 Attitude Calibration .....	26

## Disclaimer and Warning

Thank you for purchasing RadioLink 3D fixed wing A560.

To fully enjoy the benefits of this product and ensure safety, please read the manual carefully and set up the device as instructed steps. This product is not a toy and is **NOT** suitable for children under the age of 14. Adults should keep the product out of the reach of children and exercise caution when operating this product in the presence of children.

Inappropriate operation may causes property lose or accidental threats to life. Once the RadioLink product is operated, it means the operator understands this limitation of liability and accepts to take responsibility of the operation.

Make sure to follow the local laws and agree to follow the principles that made by RadioLink.

Fully understand that RadioLink cannot analyze the product damage or accident reason and cannot offer after-sales service if no flight record is provided. To the maximum extent permitted by law, RadioLink won't take any responsibility about the lose caused by indirect/consequent/accidental/special/penal damages including the lose by purchase, operation and failure of operation in any instances. Even RadioLink is informed about the possible lose in advance.

Laws in certain countries may prohibit the exemption from the terms of the guarantee. Therefore consumer rights in different countries may vary.

In compliance with laws and regulations, RadioLink reserves the right to interpret the above terms and conditions. RadioLink reserves the right to update, change or terminate these terms without prior notice.

## Warning

1. Please do not fly in the rain! Rain or moisture may cause flight instability or even loss of control. Never fly if there is lightning. It is recommended to fly in conditions with good weather (No rain, fog, lightning, wind).
2. When flying, you must strictly abide by local laws and regulations and fly safely! Do not fly in no-fly areas such as airports, military bases, etc.
3. Please fly in an open field away from crowds and buildings.
4. Please be very careful when flying indoors. You can fly in Vertical Mode for small venues. The specific flight mode should be determined according to the size of the flight venue.
5. Do not perform any operation under the condition of drinking, fatigue or other poor mental state. Please operate in strict accordance with the product manual.
6. Please be cautious when flying near electromagnetic interference sources, including but not limited to: high-voltage power lines, high-voltage transmission stations, mobile phone base stations and TV broadcast signal towers. When flying in the above-mentioned places, the wireless transmission performance of the remote control may be affected by interference. If there is too much interference, the signal transmission of the remote control and the receiver may be interrupted, resulting in a crash.

## Packing List

Items	Picture	PNP	RTF
Fuselage EPP 5mm 560mm		1	1
Wing EPP 5mm 560mm		1	1
Tail (Horizontal Stabilizer) EPP		1	1
RadioLink Transmitter T8S		0	1
RadioLink Receiver R8FM		0	1
RadioLink Flight controller Byme-A		1	1
FULLYMAX 2S 7.4V 660mAh LiPo Battery		1	1
Motor SZ-SPEED 2206F-1450KV		1	1
FLYCOLOR 15A brushless ESC		1	1
Propellers GEMFAN 8038 pore dia.3mm		2	2
Aileron Servo EMAX ES08A with 54mm Rudder Arm		1	1
Tail Servo CYS 4.3g		2	2
G.T. Power A3 Charger for 2S-3S LiPo Battery		0	1
Landing Gear		1	1
Button to fix Aileron/tail		5	5
Rudder Band to fix propeller		5	5
2.0 Cross Screwdriver		1	1
Spare Fiber Tape		1	1
Spare Clasp for drawbar/rod		2	2
Instruction Manual		2	2
Waterproof Package(With shoulder strap)		1	1

## Chapter 1 General Introduction

### 1.1 Motion Principle of Fixed Wing

As below picture shown, besides the propeller, the two ailerons/horizontal tail/vertical tail are also the moving parts of A560.

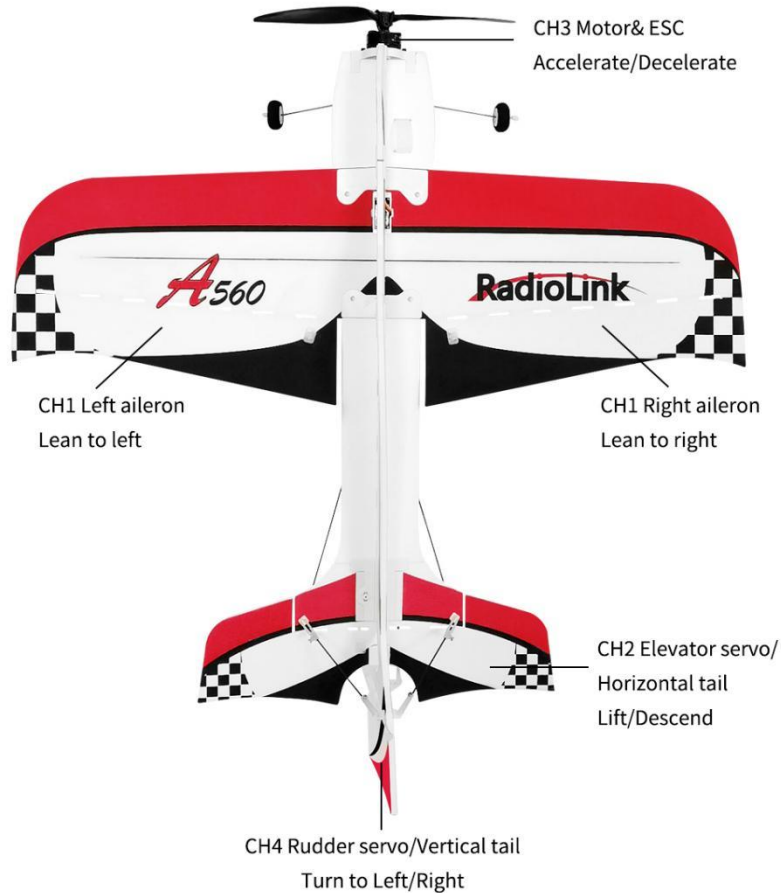

#### 1.1.1 Aileron

Ailerons are controlled by a servo. When the left aileron moves up and the right down, left aileron gets pushed by airflow downward and the right aileron is pushed by airflow upward, then A560 will lean to left or roll over to left. When the left aileron moves down and the right up, left aileron gets pushed by airflow upward and the right aileron is pushed downward, then A560 will lean to right or roll over to right.

#### 1.1.2 Elevator Servo/Horizontal Tail

When the elevator servo moves upward, the horizontal tail gets pushed downward by airflow and the head of A560 will go up. When the elevator servo moves downward, the horizontal tail gets pushed upward by airflow and the head of A560 will go down.

#### 1.1.3 Rudder Servo/Vertical Tail

Similar to elevator servo, when rudder servo moves left, the vertical tail gets pushed to right by

airflow and the head of A560 will turn left. When rudder servo moves right, the vertical tail gets pushed to left and the head of A560 will turn right.

**Note** The direction mentioned above is relative to aircraft instead of the ground. That is, if the aircraft is reversed (body upside down), its above is the ground instead of the sky/ceiling. When there's no flight controller assisting or at MANUAL MODE, if maximize the elevator servo, the aircraft will roll over like roller coaster instead of moving upward. When under the assistance of the flight controller with VERTICAL MODE or STABILIZE MODE, the max pitch angle is limited. The aircraft will keep heading upward instead of rolling over if the elevator servo is maximized.

Besides, the function of all servos are related to the motor/throttle (propeller rotation speed). Because if the aircraft moves faster, the airflow applies more force on the servos.

### 1.1.4 Drive Principle

Servo outputs signal and voltage by receiver and adjust corresponding angle in real time. Generally, angle that servo can adjust is no more than 90°.

## 1.2 A560 Units

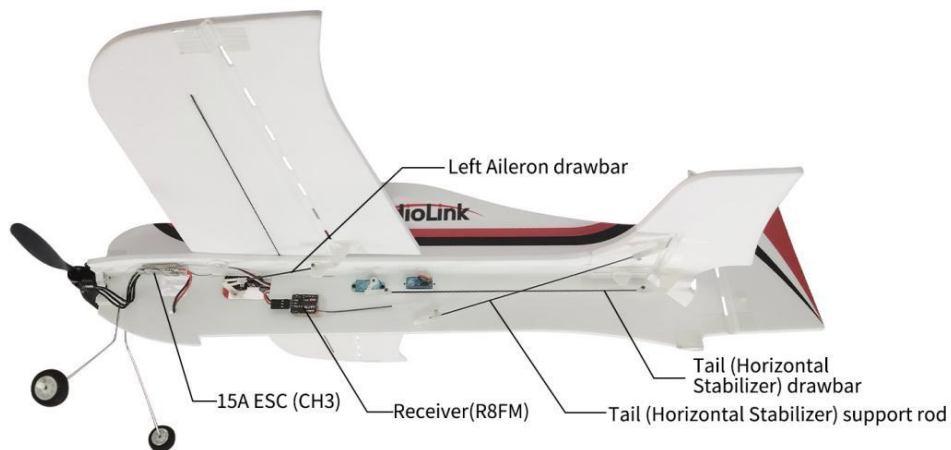
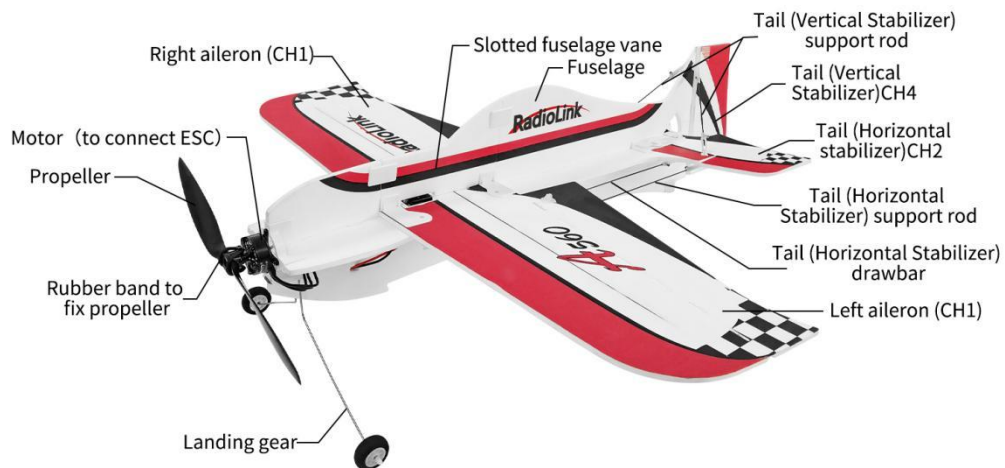

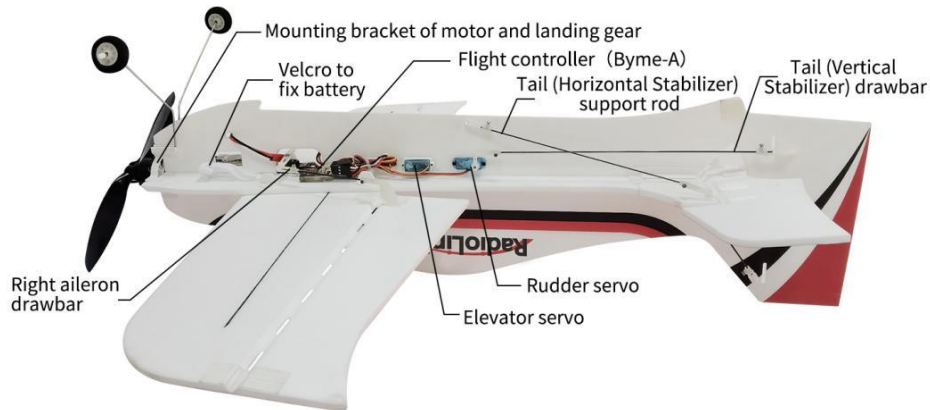

## 1.3 Usage of A560 Units

### 1.3.1 Notice for Use

No foreign matter such as water, oil, sand etc inside the aircraft.

Make sure the complete device incl. aircraft and transmitter, battery functions well.

Never self-change the aircraft or related parts. Or it may influence its functionality and possibly cause flight accident.

### 1.3.2 Transmitter & Receiver

A560 RTF(Ready To Fly) is packed with RadioLink 8-channel transmitter T8S and mini receiver R8FM, with the stable control distance up to 2000 meters. (Maximum range tested in unobstructed areas free of interference and may vary depending on local regulations.)

If it is the PNP version purchased, please refer to the manuals of the transmitter and receiver used for more details.

#### Joystick Mode

To beginners, it's very important to understand what joysticks connect to different channels and choose the most suitable mode .

First, throttle is controlled by toggling joystick up(top-max 100%) and down (bottom-min 0%). Below explanation takes MODE 2 with throttle joystick on left as example.

*Left Joystick:* Toggle up and down to control the motor (up as accelerate while down as decelerate). Toggle left and right to control the rudder (left as anticlockwise while right as clockwise).

*Right Joystick:* Toggle up and down to control the elevator servo(up as descend while down to lift the fixed wing). Toggle left and right to control the aileron servo( left to make the fixed wing rolling to left while right as rolling to right)



MODE 2



Usage of T8S Transmitter:

- Make sure the transmitter power is fully charged.
- If transmitter is changed, binding process needs to be redone before use. Please refer to the user manual of T8S for more details. You can visit RadioLink official website for detailed user manual of T8S: [https://www.radiolink.com/t8s\\_manual](https://www.radiolink.com/t8s_manual)
- Make sure to power off the aircraft before the transmitter when landing.

### 1.3.3 Flight Controller Byme-A

A560 RTF version is with flight controller Byme-A installed by default. When installing or replacing the flight controller, make sure the arrow on Byme-A points to the aircraft head with the 3M paste on the aircraft. It is advised to install the flight controller close to the core of the aircraft and connect the servo wires, ESC and receiver cables to the corresponding flight controller pin.

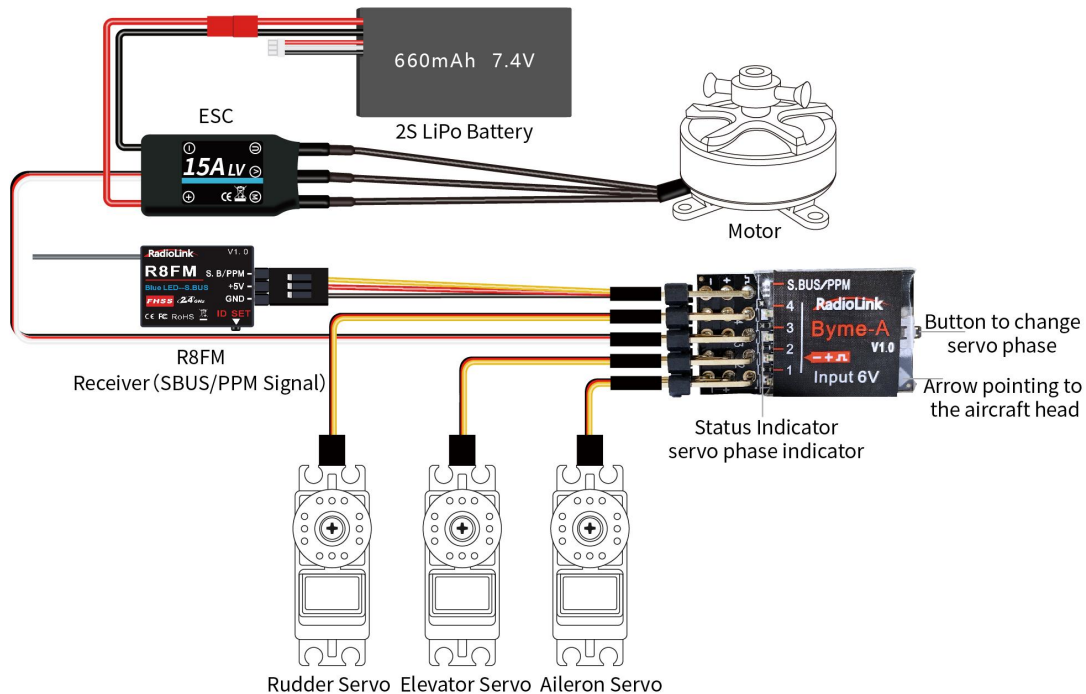

Channels on Byme-A flight controller: CH1-Aileron, CH2-Elevator, CH3-Throttle, CH4-Rudder, S.BUS/PPM-connect to receiver, SBUS/PPM signal supported.

### 1.3.4 Motor

Motor installed on A560 is SZ 2206F 1500KV brushless motor. (Motor with higher KV value, means higher rotation speed and smaller torsion force, suits smaller propeller.)

Usage of Motor:

- Make sure motors are installed tightly and rotate smoothly. If fail to rotate, stop operating transmitter immediately and pull the throttle to the bottom position in case of possible damage to motors.
- Never self-change the motor structure.
- When motors stop rotating, never touch it at once, otherwise may get burnt.
- Never cover the air vent on the motor. Make sure no foreign matter inside the motors.
- Make sure motors completely stop before powering off the aircraft and the transmitter.

### 1.3.5 ESC

The function of ESC is to change the direct current to alternating one to power supply motor and change its rotation speed basing on the throttle command. Another function of ESC is to lower the model voltage to 5V for receiver as the battery applied for A560 is 7.4V 2S LiPo Battery. Therefore, there are three wires of ESC respectively for battery, motor and receiver. ESC applied in A560 is FLYCOLOR 15A brushless ESC.

Usage of ESC:

Make sure there's a tone from ESC when power on the aircraft.

### 1.3.6 Servo

A560 uses a EMAX 8G servo as aileron servo and 2 pieces of 4.3G servo for elevator servo and rudder servo respectively.

### 1.3.7 Propeller

A560 adopts GEMFAN 8030 propeller, which is installed by factory default. If new propeller needs to be changed, fix the propeller and motor with a rubber band.

Propeller need to be identified correctly. If forward and reverse mistaken, the aircraft couldn't take off even maximize the throttle. The rotation direction of motor and propeller should be the same. That is, if the motor rotates clockwise, so is the propeller.

A560 is standard packed with 2 GEMFAN 8038 propellers. If you need to replace the propeller, please put the below No. 2 propeller ring into the propeller, as shown in the following pictures.

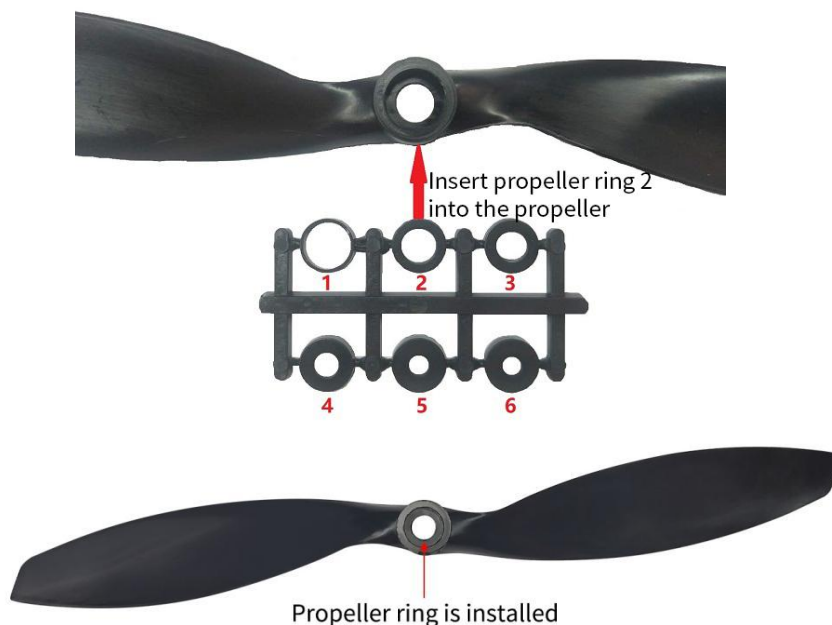

Usage of propeller:

- Make sure to check the propeller is in good condition before flight. If aged, damaged or deformed, please change to good one then flight.
- Make sure to disconnect the power supply before touching the propeller.
- As propeller is thin, use tools to (un)install if necessary and be careful to avoid accidental

scratch.

- Make sure propeller is installed well and tight before flight.
- Do not get close to rotating propeller and motor (for example, to pick up a landing plane by hand ) to avoid cuts

### 1.3.8 Battery

A560 supports 2S-3S LiPo battery. A560 is packed with FULLYMAX 2S 7.4V 660mAh LiPo Battery. With 660mAh LiPo battery fully charged, pilots can enjoy vertical flight for 10 minutes while level flight for 15 minutes.

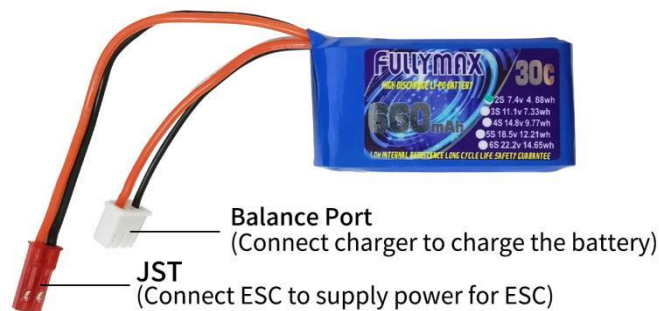

Usage of battery:

- Make sure the power connection of transmitter and aircraft is dry.
- Make sure the transmitter and aircraft are fully charged.
- When A560 flies for about 10 minutes, if the power of the aircraft drops when the throttle is pushed, the battery voltage on the aircraft is insufficient. At this time, please return to the flight immediately to avoid the failure of the aircraft to return due to the insufficient power battery voltage and the over-discharge of the battery.

### 1.3.9 Charger

A560 is packed with a G.T. Power A3 charger to charge the battery.



The following are the instructions for using the charger:

1. First, please connect A3 charger to the power supply with the standard power cord. After the right connection, three LED indicators will turn green and flash, which indicates that the charger is in good condition.
2. Second, insert the balance port of the standard 2S lithium battery of A560 into the 2S battery balance port of the charger. Then the LED indicators turns red, which means it starts to charge the battery.
3. When all the LED indicators turn solid green, charging completes and the charger will automatically stop charging.
4. Unplug the battery and then disconnect the power supply.

## Chapter 2 A560 Assembly

All electronic components of A560 RTF have been debugged and the aileron and tail (Horizontal Stabilizer) are not assembled by factory default. Please follow the packed A560 Assembly & Disassembly Instruction to complete the assembly of the aileron and tail (Horizontal Stabilizer). You can also view the assembly tutorial on RadioLink official website:[https://www.radiolink.com/a560\\_video](https://www.radiolink.com/a560_video)

## Chapter 3 Flight Mode

### 3.1 Flight Mode Setting

With the three-axis gyroscope and three-axis acceleration sensor and the full attitude algorithm, control algorithm and digital filter, the integrated flight controller Byme-A specially for 3D fixed wing, is different from traditional manual mode. Working with gyro to assist stabilization, Byme-A makes the flight much easier.

There are five flight modes: Vertical Mode, Stabilize Mode, Gyro Mode, Acrobat Mode, Manual Mode.

No.	Flight Mode	Brief	Switch Position
1	Stabilize Mode	Flight controller assists to balance aircraft. When joystick back to center, aircraft will back to level. There's max roll angle and pitch angle.	CH7- DOWN , CH5-DOWN
2	Gyro Mode	flight controller assists to balance aircraft. When joystick back to center, aircraft will NOT back to level.	CH7-DOWN , CH5-CENT
3	Manual Mode	No flight controller or gyro assist to balance. The most advanced level for professionals.	CH7-DOWN , CH5- UP CH7-UP , CH5-UP
4	Acrobat Mode	Combination of Stabilize Mode and Gyro Mode. When joystick is back to center, aircraft will back to level. There's NO max roll angle or pitch angle. Rolling over is possible.	CH7-UP , CH5-CENT

5	Vertical Mode	Stabilization achieved by flight controller . One switch to flight vertically.	CH7-UP , CH5-DOWN
---	---------------	--	----------------------

Flight modes are set by CH5(3-way switch SWB) and CH7(3-way switch SWA) as below.

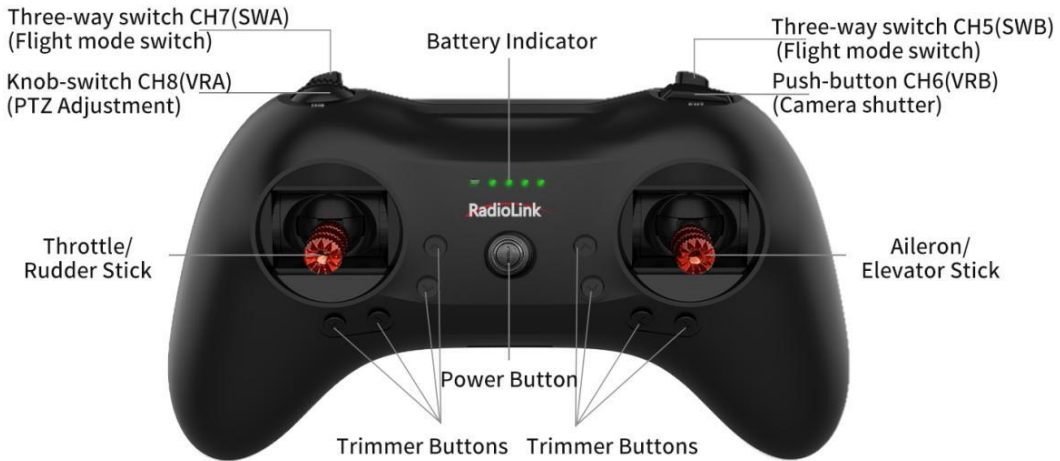

Mode 2

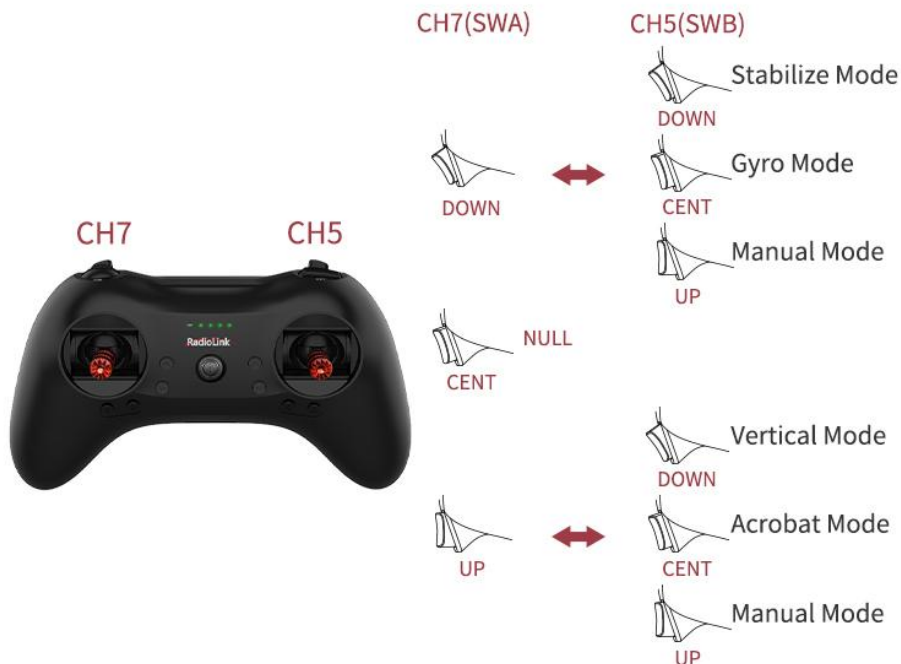

### 3.2 Five Flight Modes

#### 3.2.1 Vertical Mode

Vertical Flight Mode can be changed with one switch and control as multicopter, pilots can make the fixed wing automatically fly with the vertical posture. Tutorial video can be checked via <https://youtu.be/N2Gm4OUhu-c>

At this mode, A560 will keep vertical attitude automatically. The attitude algorithm of flight

controller will convert the joystick output to the horizontal coordinates and control with full posture.

Below is the picture illustration with Mode 2 as example:

When the aircraft is vertical, toggle the aileron joystick(CH1) to control the aircraft moving left or right.



When the aircraft is vertical, toggle the elevator joystick(CH2) to control the aircraft moving forward or backward.

**Note** If keep toggling this joystick upward, the aircraft will flight forward with a certain angle.



When the aircraft is vertical, toggle the rudder joystick(CH4) to control the aircraft moving (anti)clockwise.



If toggle the throttle joystick(CH3) upward, A560 rises vertically; toggle the throttle joystick downward, A560 descends vertically.

In Vertical Mode, push the elevator joystick, A560 can also fly horizontally. The control logic is the same as that in Stabilize Mode.

### 3.2.2 Stabilize Mode

Different from manual control, Stabilize Mode with flight controller balancing, is suitable for beginners to practice level flight.

The model attitude (inclination angles) is controlled by joysticks. When the joystick is back to central point, A560 will level. The max inclination angle is  $70^\circ$  for rolling while that for pitching is  $45^\circ$ .

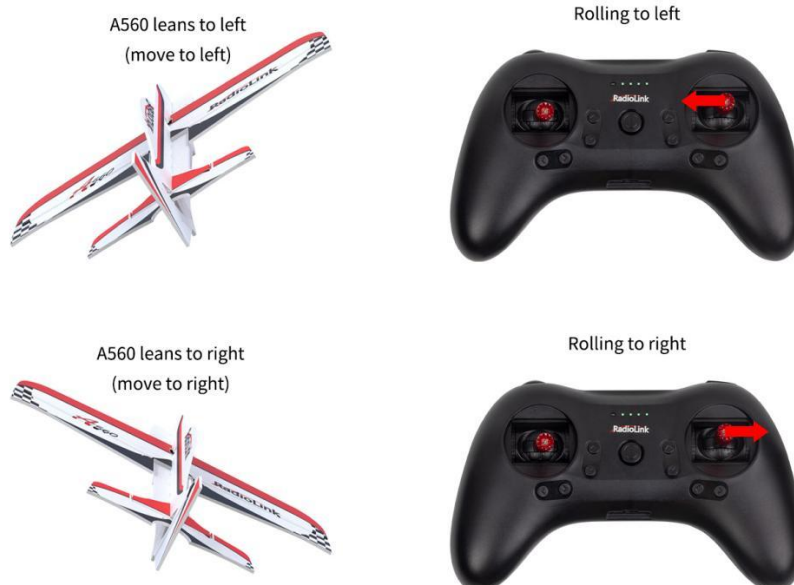

A560 head lifts  
(ascend)



Pitching downward



A560 head pressed  
(desend)



Pitching upward



A560 turns left



Rudder to Left



A560 turns right



Rudder to right



If the throttle (joystick on left) is toggled upward, A560 accelerates. If toggled downward, A560 decelerates.

### 3.2.3 Gyro Mode

At this more advanced mode, the integrated three-axis gyro assists to increase the stability. But A560 won't level even the joystick is back to central point. The joystick controls the rotation (angle speed) of the aircraft. That is, when rolling, pitching or rudder joystick is toggled, A560 will rotate with the corresponding speed.



### 3.2.4 Acrobat Mode

Combination of Stabilize Mode and Gyro Mode makes it easy to realize various free styles such as rolling, rapid pitching, backward, side flight and spiral descending.

A560 will level when the joystick is back to central point. If the joystick is toggled with small range, A560 will move to the corresponding directions.

When toggle joysticks with large range, aircraft will rotate to the corresponding directions.

### 3.2.5 Manual Mode

No assistance from flight controller algorithm or gyro, all flight movements are realized manually, which requires the most advanced skills.

It's strongly advised for beginners to choose Vertical Mode or Stabilize Mode to practice. Or if in small space, Vertical Mode can be set to take off and land then switch to level flight(Stabilize Mode/Gyro Mode/Acrobat Mode/Manual Mode) when reach a certain height. If switch to other flight modes from Vertical Mode, remember to pull the elevator joystick to ensure rising of A560. Otherwise the aircraft will crash.

When at Vertical Mode, the joystick operation is same as that of multi-copters.

When at Stabilize Mode/Gyro Mode/Acrobat Mode/Manual Mode, the joystick operation is standard one of fixed wing. Beginners have better to practice with simulators and get familiar to the operations of aileron/elevator/throttle/rudder joysticks in advance.

## Chapter 4 Flight Precautions

1. Check before take-off to make sure that all parts are in good working condition.
2. Make sure that the buttons(to fix aileron/tail) are firmly fixed to avoid the crash caused by the loose buttons.
3. Make sure the battery is fully charged and properly bound to the fuselage before take-off.
4. Make sure that the front and back of the propeller are installed correctly and the propeller is not inclined.
5. Keep A560 face up, rather than upside down during power-on calibration and attitude calibration.
6. After the setting of channel direction in the transmitter, please calibrate the attitude once. Then switch to the manual mode, and push the joystick to check whether the movement of the control surface is correct. If it is not, please change the direction of the corresponding channel on the flight controller.
7. In Stabilize/Gyro/Acrobat mode, the aileron may swing by itself to assist the balance due to the gyroscope involved in stabilization, which is a normal phenomenon.
8. In Manual mode, it is normal that there is no movement of the control surface without any operation on the transmitter because there is no gyroscope involved in stabilization.
9. If flying indoors, please choose the Vertical mode (same as multi-rotor operation). Five flight modes are available for outdoor flight. It is recommended that novices choose the Stabilize mode for take-off and practice.
10. It is recommended that a single flight not exceed 15 minutes when the battery is fully charged to avoid over-discharge of the battery.
11. If there is any abnormality during the flight, please land immediately and find out the reason.

## Chapter 5 Servo Phase

### 5.1 Transmitter Phase

#### 5.1.1 Transmitter Phase Setup

A560 RTF version has already set up transmitter phase, but please check it again before taking off. Please check the transmitter phase in T8S Parameter Setup APP. Enter the basic menu. Set CH1/CH2/CH4 to NORM, and CH3 to REV, as shown below:

Disconnect							READ							WRITE							STORE							LOAD						
SERVO		BASIC		ADVANCED		SYSTEM1		TX: 3.0V		EXT: 0.0V		RSSI: null																						
-CH-	-REV-	-SUB-	-EPA-L	-EPA-R	-F/S-	DELAY																												
CH1:	NORM	0	96	96	50	100																												
CH2:	NORM	0	96	96	50	100																												
CH3:	REV	0	96	96	0	100																												
CH4:	NORM	0	96	96	50	100																												
CH5:	NORM	0	96	96	50	100																												
CH6:	NORM	0	96	96	50	100																												
CH7:	NORM	0	96	96	50	100																												
CH8:	NORM	0	96	96	50	100																												

Click [https://www.radiolink.com/t8s\\_apps](https://www.radiolink.com/t8s_apps) to download T8S Parameter Setup APP and click [https://www.radiolink.com/t8s\\_manual](https://www.radiolink.com/t8s_manual) to download the detailed manual of T8S in RadioLink official website.

#### Note

1. After the phase setting in T8S transmitter, please refer to **6.2 Attitude Calibration** to calibrate the attitude once, and then check the transmitter phase.
2. After the phase setting in T8S transmitter, please keep the setting and do not make any modifications. If the control surface of the aircraft moves incorrectly when pushing the stick, please change the direction of the corresponding channel on the flight controller.

#### 5.1.2 Transmitter Phase Test

After completing the phase setting in T8S transmitter and an attitude calibration, please check whether the transmitter phase is correct. Make sure to switch to MANUAL MODE(eg. T8S CH7-DOWN, CH5-UP) to check phases are correct before each flight. Below Mode 2 is explained as example.

##### ( 1 ) Aileron phase

Toggle the aileron joystick to left, left aileron is lifted and right one is pressed; toggle the joystick to right, left aileron is pressed and right one is lifted, meaning the aileron phase is correct.

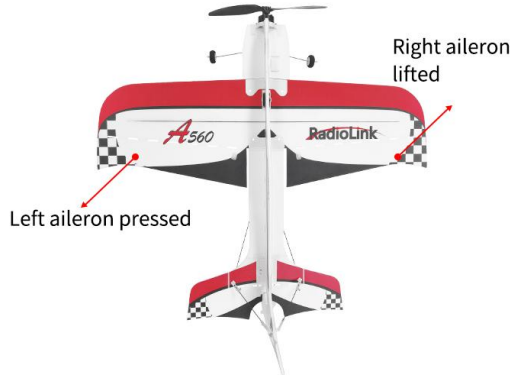
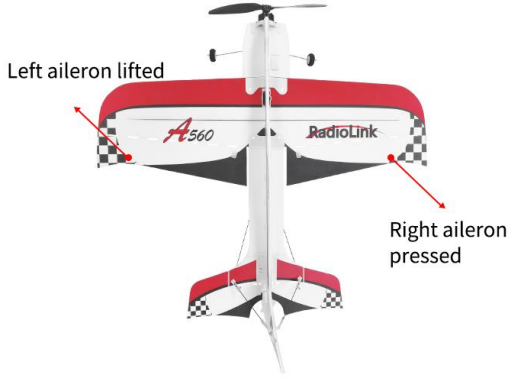

( 2 ) Elevator phase

Toggle the elevator joystick downward, elevator servo(horizontal tail) is lifted; toggle the joystick upward, elevator servo(horizontal tail) is pressed, meaning the elevator phase is correct.



( 3 ) Rudder Phase

Toggle the rudder joystick to left, rudder servo(vertical tail) turns to left; toggle the joystick to right, rudder servo(vertical tail) turns to right, meaning the rudder phase is correct.



( 4 ) Throttle Phase

Toggle the throttle joystick to the bottom and the motor stays still. Gently push the throttle stick upward, motor moves faster and faster, meaning throttle servo correct.

5.1.3 Transmitter Phase Adjustment

If transmitter phase is reversed, the phase needs to be adjusted by the flight controller. Press the button on the front of the flight controller Byme-A to change the phase. The adjustment method is as follows:

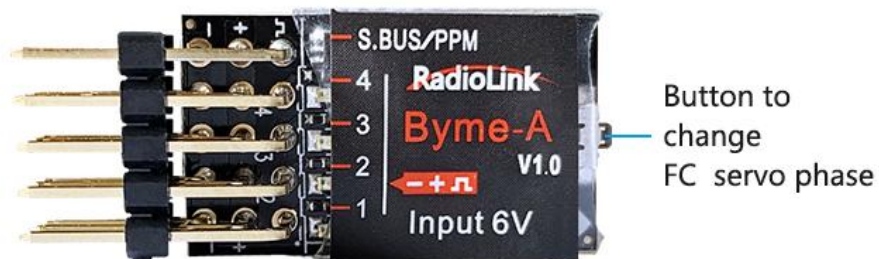

No.	Channel	If phase is reversed	Indicator LED
1	AIL	Short press the button once	Green LED to CH1 on/off
2	ELEV	Short press the button twice	Green LED to CH2 on/off
3	THRO	N/A	Green LED always on
4	RUDD	Short press the button four times	Green LED to CH4 on/off

### Note

1. Make sure attitude calibration is done before servo phase calibration. Because flight controller will auto identify NOR/REV and modify gyro direction when doing attitude calibration.
2. Neither the always-on nor off green LED means reversed phase. Only toggle the joysticks can check if the corresponding servo phases are reversed.

## 5.2 Flight Controller Phase

### 5.2.1 Flight Controller Phase Test

After checking the right transmitter phase, it is necessary to check the flight controller phase of A560. (The transmitter phase must be checked first, and then flight controller phase.) Make sure to switch to STABILIZE MODE (eg. T8S CH7-DOWN, CH5-DOWN) to check flight controller phases are correct before each flight. Below Mode 2 is explained as example.

#### ( 1 ) Aileron phase on flight controller

Toggle the aileron joystick to left, left aileron is lifted and right one is pressed; toggle the joystick to right, left aileron is pressed and right one is lifted, meaning the aileron phase on flight controller is correct.

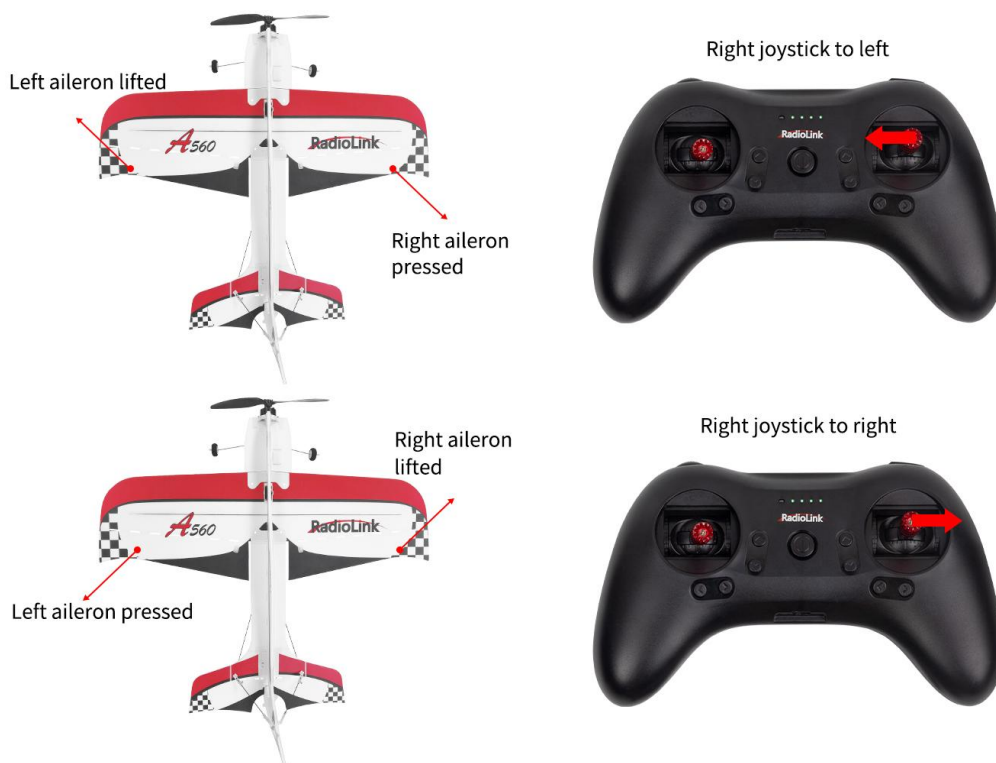

#### ( 2 ) Elevator phase on flight controller

Toggle the elevator joystick downward, elevator servo(horizontal tail) is lifted; toggle the joystick upward, elevator servo(horizontal tail) is pressed, meaning the elevator phase on flight controller is correct.



### ( 3 ) Rudder Phase on flight controller

Toggle the rudder joystick to left, rudder servo(vertical tail) turns to left; toggle the joystick to right, rudder servo(vertical tail) turns to right, meaning the rudder phase on flight controller is correct.



### 5.2.2 Flight Controller Phase Adjustment

If flight controller phase is reversed, the phase needs to be adjusted by the flight controller. The adjustment method is the same as the transmitter phase adjustment method. For details, please refer to [5.1.3 Transmitter Phase Adjustment](#).

## Chapter 6 Flight Controller Calibration

### 6.1 Power-on Calibration

(1) Push the throttle stick of the transmitter to the lowest position first, and then power on A560. If the throttle stick is pushed to the highest position and then power on A560, the ESC will enter the calibration mode.

(2) Each time the flight controller is powered on, the flight controller will calibrate with the green LED quickly flashing, which means gyro calibration is under process. Therefore, it is recommended to install the battery first, then place the aircraft on the ground (The side of the wing with the spray painting is facing up. Please do not lie on its back), and then power on the aircraft and put the aircraft still on the ground until DEE sounds from the motor heard. When the green LED is always on means calibration done.

### 6.2 Attitude Calibration

Flight controller Byme-A needs to calibrate the attitudes/level to ensure the balance status.

(1) It is advised to place the landing gear of A560 on the standard package, which is equivalent to raising the nose at an angle of about 20 degrees, and then operate the transmitter to calibrate the attitude. Lifting up the head with a certain angle is helpful for flight balance.



(2) Push the left stick (left and down) and the right stick (right and down) as below and hold more than 3 seconds. The green LED flashes once mean the calibration completed. It is also normal for the control surface to swing or the motor to rotate once at this time.



(3) Attitude calibration will be recorded by flight controller once the it is complete with success.

# A560 (PNP) Instruction Manual

## Disclaimer and Warning

Please refer to [A560 RTF Disclaimer and Warning](#).

## Packing List

Please refer to [A560 RTF Packing List](#).

## Chapter 1 General Introduction

Please refer to [A560 RTF Chapter 1 General Introduction](#).

## Chapter 2 A560 Assembly

Please refer to [A560 RTF Chapter 2 A560 Assembly](#).

## Chapter 3 Flight Mode

### 3.1 Receiver Connection

For A560 PNP version, transmitter and receiver needs to be installed. A560 is compatible to all transmitters that supports SBUS/PPM signal.

1. First, install the receiver on A560 aircraft. Make sure the receiver is switched to SBUS/PPM signal mode, and then connect the receiver to Byme-A flight controller. For the connection method of the receiver, please refer to [A560 RTF Chapter 1.3.3 Flight Controller](#).
2. Second, calibrate the throttle range of A560 ESC. The normal Start-up and Throttle Range calibration steps of A560 ESC are as follows:

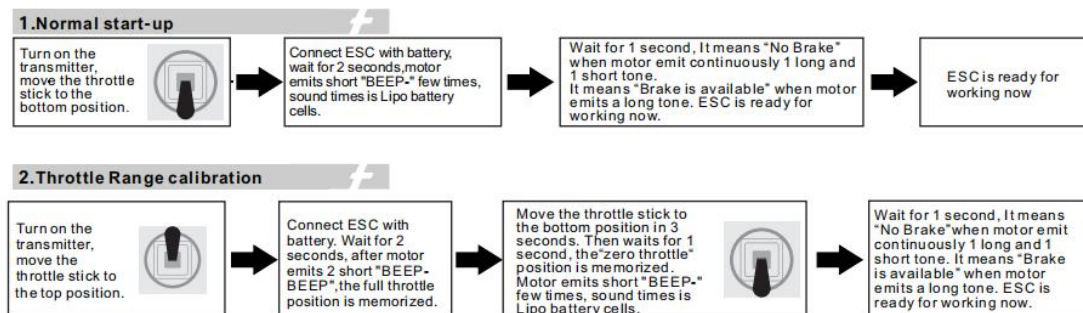

For more information on how to use A560 ESC, please visit RadioLink official website:

[https://www.radiolink.com/manuals\\_download](https://www.radiolink.com/manuals_download)



## 3.2 Transmitter Setup

### 3.2.1 Model Type Setup

For A560 PNP version, model type needs to be set as fixed wing in the transmitter. Take AT9S Pro as example( same as AT10II/AT9S/AT10/AT9).

*Steps:* Power on the transmitter - Long press Mode to enter BASIC MENU - Turn the Dial to MODEL TYPE - Press Push to enter the menu and turn Dial to select ACROBASIC - Long press Push for 1 second and a notice “ARE YOU SURE”pops out - Press Push again and a notice”Please wait...” pops out and there will be DEE sound heard, meaning setting complete.

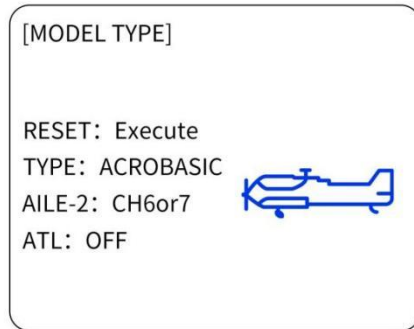

### 3.2.2 Transmitter Phase Setup

Please set the direction of CH3 to Reverse, and other channels CH1/CH2/CH4 to Normal. Take AT9S Pro as example( same as AT10II/AT9S/AT10/AT9).

*Steps:* Long press Mode to enter BASIC MENU - rotate Dial to REVERSE - Press Push to enter the menu - rotate Dial to 3:THRO - change NOR to REV - Long press Push for 1 second to confirm.

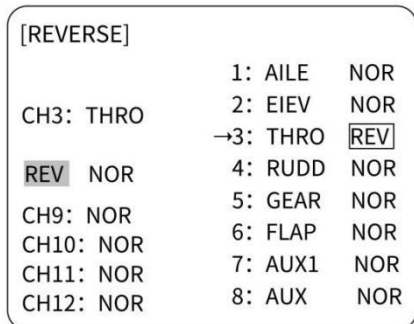

## 3.3 Flight Mode

### 3.3.1 Flight Mode Setting

With the three-axis gyroscope and three-axis acceleration sensor and the full attitude algorithm, control algorithm and digital filter, the integrated flight controller Byme-A specially for 3D fixed wing, is different from traditional manual mode. Working with gyro to assist stabilization, Byme-A makes the flight much easier.

There are five flight modes: Vertical Mode, Stabilize Mode, Gyro Mode, Acrobat Mode, Manual Mode. Flight modes are switched by CH5(3-way switch) and CH7(2-way switch) by default.

The value range of channel 5 and channel 7 corresponding to the flight mode is as shown below:

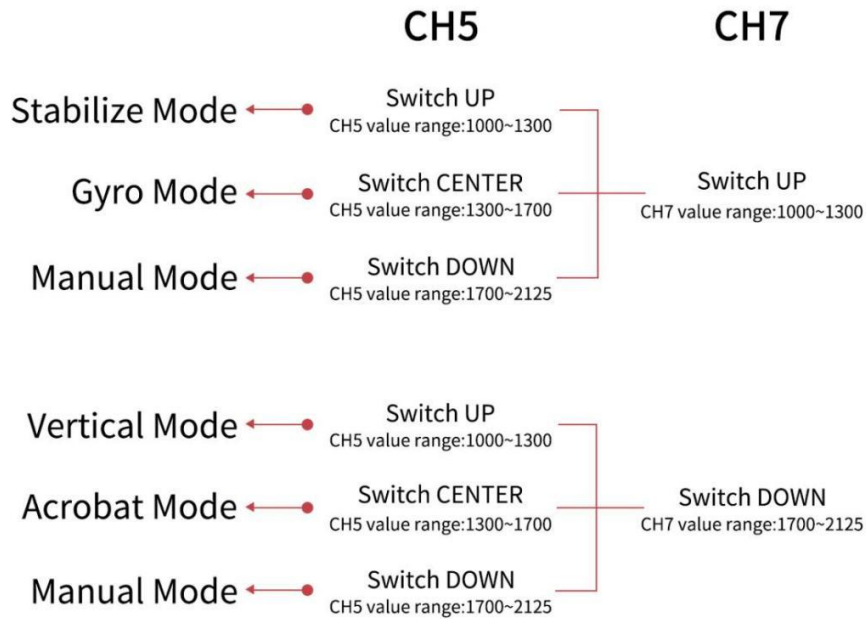

Take AT9S Pro as example. Flight modes are set by CH5(3-way switch SWC) and CH7(2-way switch SWD) as below.



### 3.3.2 Five Flight Modes

Please refer to [A560 RTF Chapter 3.2 Five Flight Modes](#).

## Chapter 4 Flight Precautions

Please refer to [A560 RTF Chapter 4 Flight Precautions](#).

## Chapter 5 Servo Phase

Please refer to [A560 RTF Chapter 5 Servo Phase](#).

## Chapter 6 Flight Controller Calibration

### 6.1 Power-on Calibration

Please refer to [A560 RTF Chapter 6 Power-on Calibration](#).

### 6.2 Attitude Calibration

Flight controller Byme-A needs to calibrate the attitudes/level to ensure the balance status.

(1) It is advised to place the landing gear of A560 on the standard package, which is equivalent to raising the nose at an angle of about 20 degrees, and then operate the transmitter to calibrate the attitude. Lifting up the head with a certain angle is helpful for flight balance.



(2) Push the left stick (left and down) and the right stick (right and down) as below and hold more than 3 seconds. The green led flashes once mean the calibration completed. It is also normal for the control surface to swing or the motor to rotate once at this time.

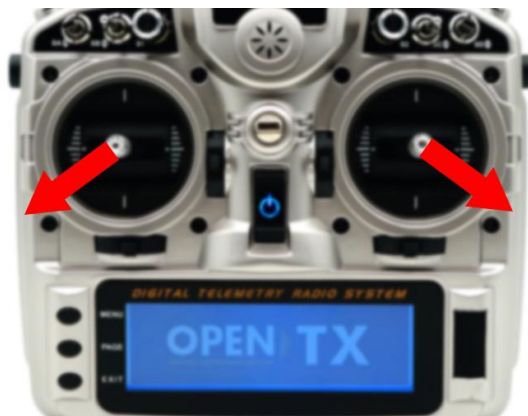

**Note:** When using a non-RadioLink transmitter, if the attitude calibration is unsuccessful when pushing the left stick (left and down) and the right stick (right and down), please change the direction of the channel in the transmitter. Make sure when pushing the joystick as above, the value range of channel 1 to channel 4 is:

CH1 2000  $\mu$ s, CH2 2000  $\mu$ s, CH3 1000  $\mu$ s, CH4 1000  $\mu$ s

Take an open source transmitter as example. The servo display of channel 1 to channel 4 when calibrating the attitude successfully is as shown below:

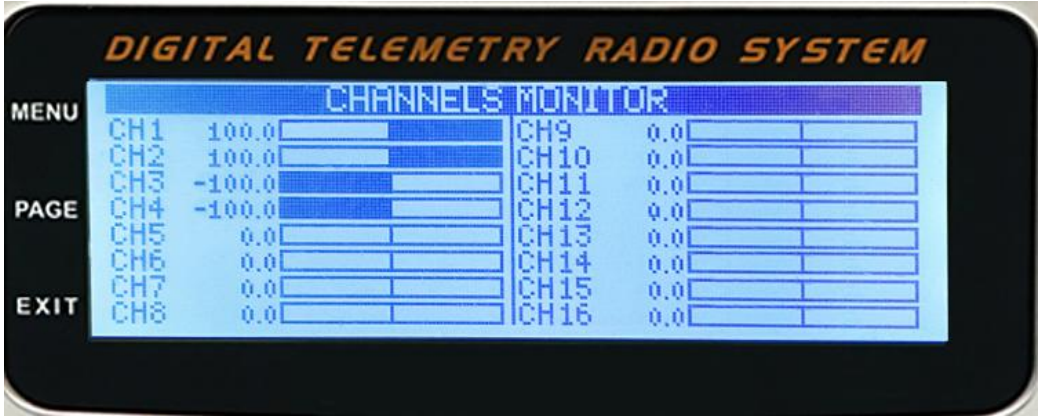

CH1 2000  $\mu$ s (opentx +100), CH2 2000  $\mu$ s (opentx +100)  
CH3 1000  $\mu$ s (opentx -100), CH4 1000  $\mu$ s (opentx -100)

(3) Attitude calibration will be recorded by flight controller once the it is complete with success.

**Thank you again for using RadioLink products!**